

T401/501

Foldable Treadmill

Owner's Manual



Retain this owner's manual for future reference.
Read and follow all instructions in this owner's manual.

T401/T501 INTRODUCTION



KEY FEATURES

CAUTION!

Before beginning any exercise program, always consult your physician. If you experience chest pains, nausea, dizziness or shortness of breath, STOP exercising and consult your physician before continuing.

Congratulations on choosing a state-of-the-art treadmill.

You have taken the first step to a healthier and more rewarding lifestyle.

This treadmill is especially modern and sleek design to give you reliable performance and enjoyable workout in the comforts of your home. Please find below the features and benefits of this treadmill.

- ◇ Compact frame to take up less space and 78-degree-fold design is better for space saving.
- ◇ The base frame is hidden below the main frame to maximize the running surface size.
- ◇ Gas assisted lift makes folding and unfolding of the deck safe and easy.
- ◇ The folding lock release mechanism is located at the end of the deck so that when folded, only adults can access the release.
- ◇ Wireless pulse receiver compatible with Polar and CardioSport chest straps to monitor your heart rate during exercise.
- ◇ Low impact design with cushions so that your joints are protected against injury.
- ◇ Self-centering belt alignment so that the running belt is always tracked correctly in the center.

TABLE OF CONTENTS

I.	IMPORTANT SAFETY PRECAUTIONS	4
	Grounding Instructions	
	Electrical Safety	
	Mechanical Safety	
	Appropriate Attire	
	Children and Pets	
II.	SETTING UP YOUR TREADMILL	6
	Placement in Your Home	
	Leveling the Base	
	Use Dedicated Circuit	
III.	ASSEMBLY INSTRUCTIONS	8
	Tools and Accessories	
	Hardware Kit Content	
	Step by Step Instruction	
IV.	HANDLING YOUR TREADMILL	10
	Folding and Unfolding the Treadmill	
	Moving the Treadmill	
V.	OPERATING THE TREADMILL	11
	Turn Power on	
	Safety Tether Key and Clip	
	Getting on and off the Treadmill	
VI.	OPERATING THE CONSOLE	12
VII.	EXERCISE TIPS AND GUIDELINES	18
	Stretch	
	Warm Up	
	Cool Down	
	How Often	
	How Long	
	How Hard	
	Target Heart Rate	
VIII.	MAINTENANCE	20
	Cleaning	
	Running Belt Centering Adjustment	
	Running Belt Tension Adjustment	
	Lubricating the Deck	
IX.	TROUBLE SHOOTING	22
	When to Call for Help	
	Trouble Shooting Guide	
X.	WARRANTY	23

I. IMPORTANT SAFETY PRECAUTIONS

When using an electrical product, basic precautions should always be followed. Read all instructions before using this treadmill.

WARNING!

Connect this unit to a properly grounded outlet only.

GROUNDING INSTRUCTIONS

This product must be grounded! If treadmill should malfunction or break down, grounding provides a path of least resistance for electrical current to reduce the risk of electrical shock. This product is equipped with a cord having an equipment-grounding conductor and a grounding plug. This plug must be plugged into an appropriate outlet that is properly installed and grounded in accordance with local codes and ordinances.

DANGER!

Improper connection of the equipment-grounding conductor can result in a risk of electrical shock. Check with a qualified electrician or serviceman if you are in doubt as to whether the product is properly grounded. Do not modify the plug provided with the product – if it will not fit the outlet, have a proper outlet installed by a qualified electrician.

ELECTRICAL SAFETY

To reduce the risk of burns, fire, electrical shock or injury to persons, take the following precautions.

- DO NOT leave the treadmill unattended at any time when plugged in. Unplug the treadmill from the power source when it is not in use.
- DO NOT use the treadmill if the unit is wet or the plug or cable is damaged or the treadmill is not working properly. DO NOT use damaged or defective equipment. Keep equipment out of use until unit is repaired by trained technician.
- Keep the power cable and plug away from heated surfaces.
- NEVER place the power cord under carpeting or have any object on top of the power cord.
- ONLY use the power cord provided with this treadmill.
- To disconnect, turn the switch to the off position, then remove the plug from the outlet.

This exercise equipment is designed and built for optimum safety for the home use. However, certain precautions always apply whenever you operate any exercise equipment. Be sure to read the entire manual before assembly and operation of this machine. Also, please note the following safety precautions.

CAUTION!

STOP your workout immediately if you feel any pain or abnormal symptoms and consult your physician.

Read this manual before operating this treadmill.

MECHANICAL SAFETY

- Before you start exercise, make sure the unit functions correctly. To maintain the safety level of the exercise equipment, DO NOT use a faulty device.
- Replace defective components immediately and/or keep the equipment out of use until repair.
- Inspect the equipment prior to exercising to ensure that all nuts and bolts are fully tightened before each use.
- DO NOT use attachments not recommended by the manufacturer.
- NEVER drop or insert any object into any opening.
- ONLY one person may use the treadmill at a time.
- NEVER activate the speed when someone else is standing on the treadmill.

APPROPRIATE ATTIRE

- Always wear appropriate clothing. DO NOT wear clothing that might catch on any part of the treadmill.
- Always wear non-slippery shoes during workout with the treadmill. DO NOT wear shoes with heels or leather soles. Check the soles of your shoes and remove any dirt and embedded stones.

CHILDREN AND PETS

- Most exercise equipments are not recommended for young children. Children should not use the equipment unless they are under adult supervision. To ensure safety, keep young children off the treadmill at all times.
- Exercise equipments have many moving parts. In the interest of safety, keep others (especially children and pets) at a safe distance while you exercise.

II. SETTING UP YOUR TREADMILL

CAUTION!

Make sure the running deck is level to the ground.

If the deck is positioned on uneven surface, it would cause premature damage to the electronic system.

PLACEMENT IN YOUR HOME

To make exercise a desirable daily activity for you, the treadmill should be placed in a comfortable and convenient setting. This treadmill is designed to use minimal floor space and to go nicely in your home.

- DO NOT place the treadmill outdoors.
- DO NOT place the treadmill near water or in high moisture content environment.
- Make sure power cord is not in the path of heavy traffic.
- If your room is carpeted, check the clearance to make sure there is enough space between the carpet fiber and the treadmill deck. If you are uncertain, it is best to place a mat beneath your treadmill.
- Locate the treadmill at least 4 feet from walls or furniture.
- Allow a safety area of 2m X 1m behind the treadmill so that you can easily get on and off the treadmill without getting trapped during an emergency.

Occasionally after extended use you will find a fine black dust below your treadmill. This is normal wear and DOES NOT mean there is anything wrong with your treadmill. This dust can be easily removed with a vacuum cleaner. If you wish to prevent this dust from getting on your floor or carpet, place a mat beneath your treadmill.

LEVELING THE BASE

It is important that you place the treadmill on a firm level surface.



Check the treadmill to ensure the frame is level once you have moved the treadmill into the position of your choice.

USE DEDICATED CIRCUIT



The outlet selected should be a dedicated circuit. It is particularly important that NO sensitive electrical equipments, such as computer or TV, share the same circuit.

III. ASSEMBLY INSTRUCTIONS

TOOLS AND ACCESSORIES

	<u>Description</u>	<u>Q'ty</u>	<u>When to use</u>
	Wrench, Hex	1	For assembling steps 1 and step 2
	Power cable	1	For operating treadmill
	Safety key	1	For operating treadmill

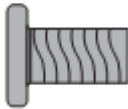
HARDWARE KIT CONTENT

	<u>#</u>	<u>Description</u>	<u>Q'ty</u>	<u>When to use</u>
	A	Screw M8x15	14	Step 1 x 8pcs Step 2 x 6pcs
	B	Washer, flat	6	Step 1 x 4pcs

STEP BY STEP INSTRUCTION

1. ASSEMBLE THE UPRIGHT POST

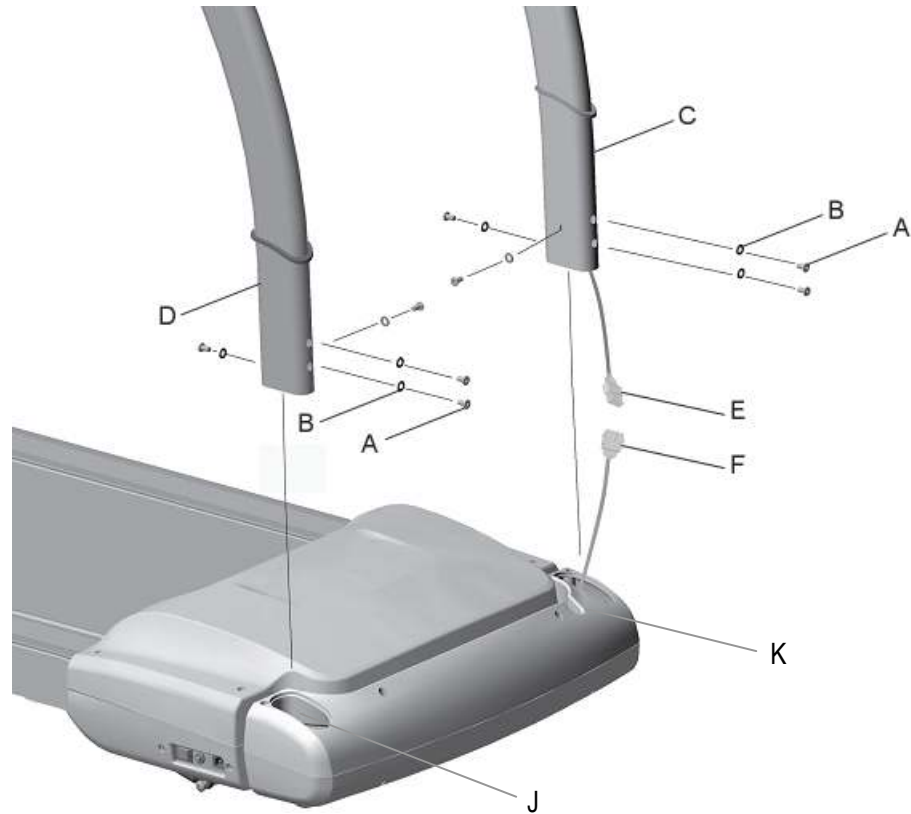

NOTE
Take care that the
cables do not get
trapped or pinched

Use Hex wrench to perform this assembly procedure.

1. Connect the cables (E, F) before you assemble the upright post (C) to base frame (K).
2. Lightly secure the upright post (C, D) to base frame (K, J) with four M8x15mm screws (A) and four flat washers (B) on two sides.
3. Tighten the eight bolts on the upright post after they are in position.

2. ASSEMBLE THE CONSOLE

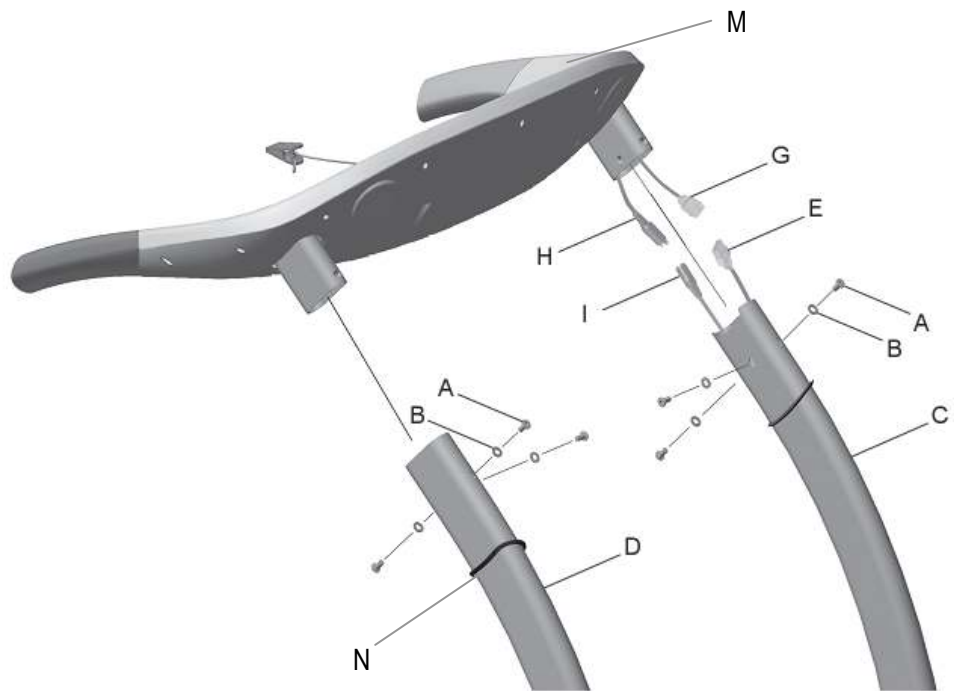

Use Hex wrench to perform this assembly procedure.

1. Connect the cables (E, G) and (H, I) before you assemble the console (M) to upright post (C,D).
2. Secure console (M) to the upright post (C, D) through the upright ring (N) with six M8x15 screw (A) and six flat washers (B). Be careful not to pinch or damage the cables.
3. Tighten all screws as tightly as possible.

IV. HANDLING YOUR TREADMILL

FOLDING THE TREADMILL

Folding and unfolding of this treadmill is made easy with the assistance of gas shock. After the treadmill has come to a complete stop, make sure the elevation is lowered all the way to the ground before folding the treadmill. With caution, fold up the deck slowly with both hands. When you hear a click, the deck is locked in place.

UNFOLDING THE TREADMILL

Pull out the lock release on the rear by left end cap with your left hand. At the same time, press the deck slowly with right hand. Use both hands to bring the deck slowly to the ground. As the deck gets closer to the ground, it will drop at a faster rate and feel heavier. Please handle with caution.

MOVING THE TREADMILL

This treadmill is easy to move around safely.

To move the treadmill:

1. Turn power switch off.
2. Unplug the power cord.
3. Make sure the deck is at 0% grade.
4. Fold the treadmill and make sure lock is engaged. You should hear a click to indicate positive engagement.
5. Simply roll the treadmill on four wheels to the desired location.

STORING THE TREADMILL

For safety precaution, especially when you have children in the house, we recommend that you follow these steps to keep the treadmill out of potential harm.

1. Turn off the power switch when you have finished workout.
2. Disconnect the plug from the wall socket.
3. Remove the safety tether key and store out of reach of children.

V. OPERATING THE TREADMILL

TURN POWER ON

WARNING!

NEVER use this treadmill without first securing the safety tether clip to your clothing.

CAUTION!

For your safety, step onto the belt when the speed is no more than 2 Km/H.

NEVER start the treadmill at a running speed and attempt to get on while it is moving fast.

NOTE!

The deck should NOT be folded unless the elevation is at 0% grade. Attempts to fold the deck while it is elevated may cause damage to the frame.

The ON/OFF switch for the treadmill is located next to the power supply cord at the back of the motor cover. Flip this switch to the "ON" position.

SAFETY TETHER KEY AND CLIP

The safety key is designed to cut the main power to the treadmill should you fall. Therefore, the safety key is designed to bring the treadmill to an immediate stop. At high speeds, it may be uncomfortable and somewhat dangerous to come to a complete stop immediately. So, use the safety key as emergency stop only. To bring the treadmill to a complete stop safely and comfortably, use the red stop button.

Your treadmill will not start unless the safety key is properly inserted into the key holder at the side of the console. The other end of the safety key should be securely clipped to your clothing so that in case you fall, you will pull the safety key from the console, which will stop the treadmill immediately to minimize injury. For your safety, never use the treadmill without securing the safety key clipped to your clothing. Pull on the safety key clip to make sure it will not come off your clothing.

GETTING ON AND OFF THE TREADMILL

Handle with care when getting on or off the treadmill. Try to use the handlebars while getting on or off. While you are preparing to use the treadmill, do not stand on the running belt. Straddle the running belt by placing your feet on both side rails of the treadmill deck. Place your foot on the belt only after the belt has begun to move at a consistent slow speed.

During exercise, keep your body and head facing forward at all times. Never attempt to turn around on the treadmill when the running belt is still moving. When you have finished exercising, stop the treadmill by pressing the red stop button. Wait until the treadmill comes to a complete stop before attempting to get off the treadmill.

If you feel uneasy with the speed and are not sure how to stop, hold the handlebars, lift your feet off the running belt and place on both sides of the side landing. The side landing is a non-moving platform and would be a good place to rest before resuming the workout. Always remember to start at a low speed for your safety and comfort.

VI. OPERATING THE CONSOLE

DISPLAY VALUES

Display	Resolution	Range	Increment
PULSE	XXX	40-240	1
ELEVATION (%)	XX	0-12	1%
DISTANCE (Miles)	XX.X	1-999	0.1
DISTANCE (Km)	XX.X	1-999	0.1
SPEED (Km/H)	XX.X	1.0 – 16.0 (T401)	0.1
	XX.X	0.8 – 18.0 (T501)	0.1
TIME	XX:XX	00:01 – 99:59	00.01
CALORIES	XXX	1-999	1

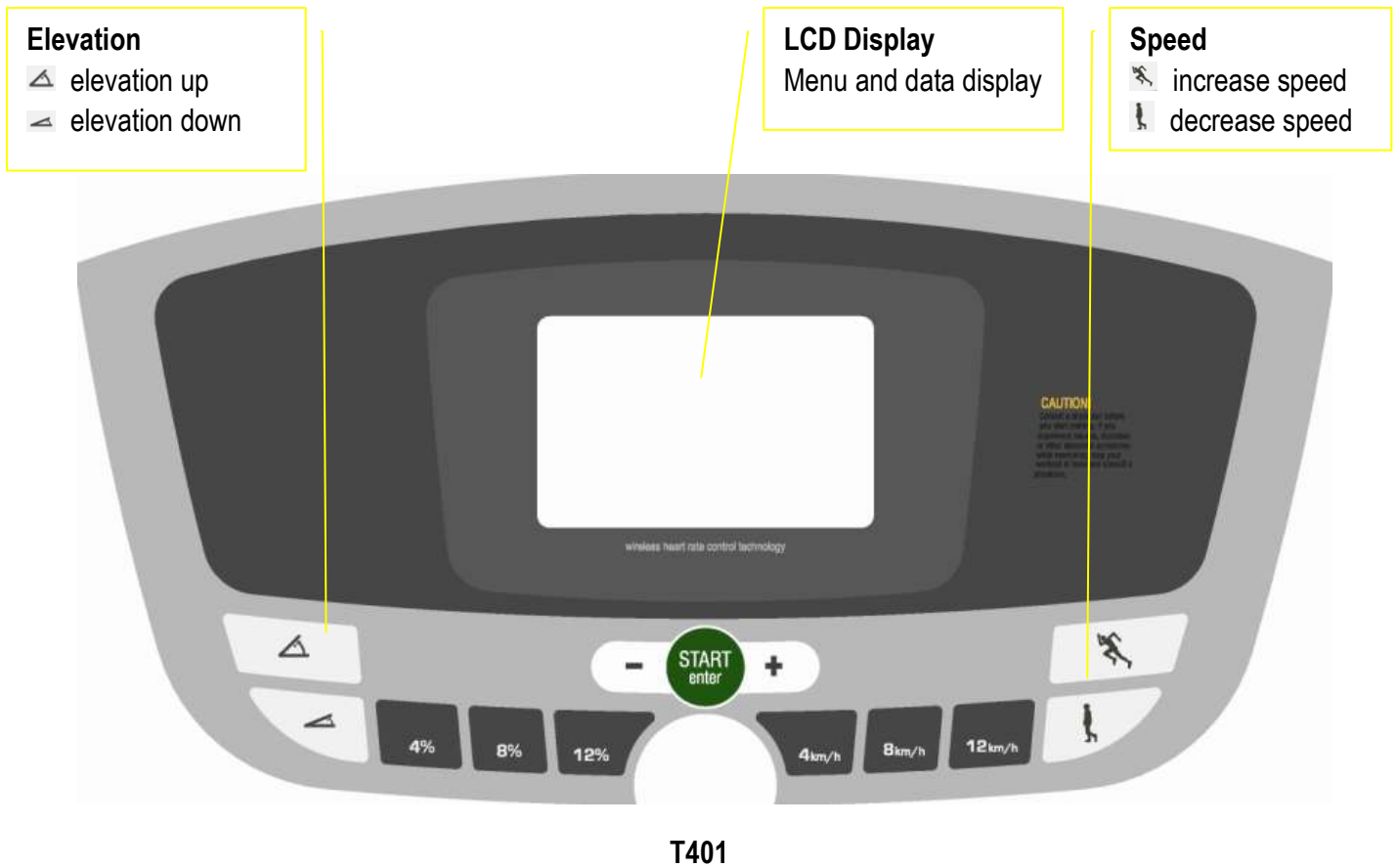

Elevation

- ▲ elevation up
- ▼ elevation down

LCD Display
Menu and data display

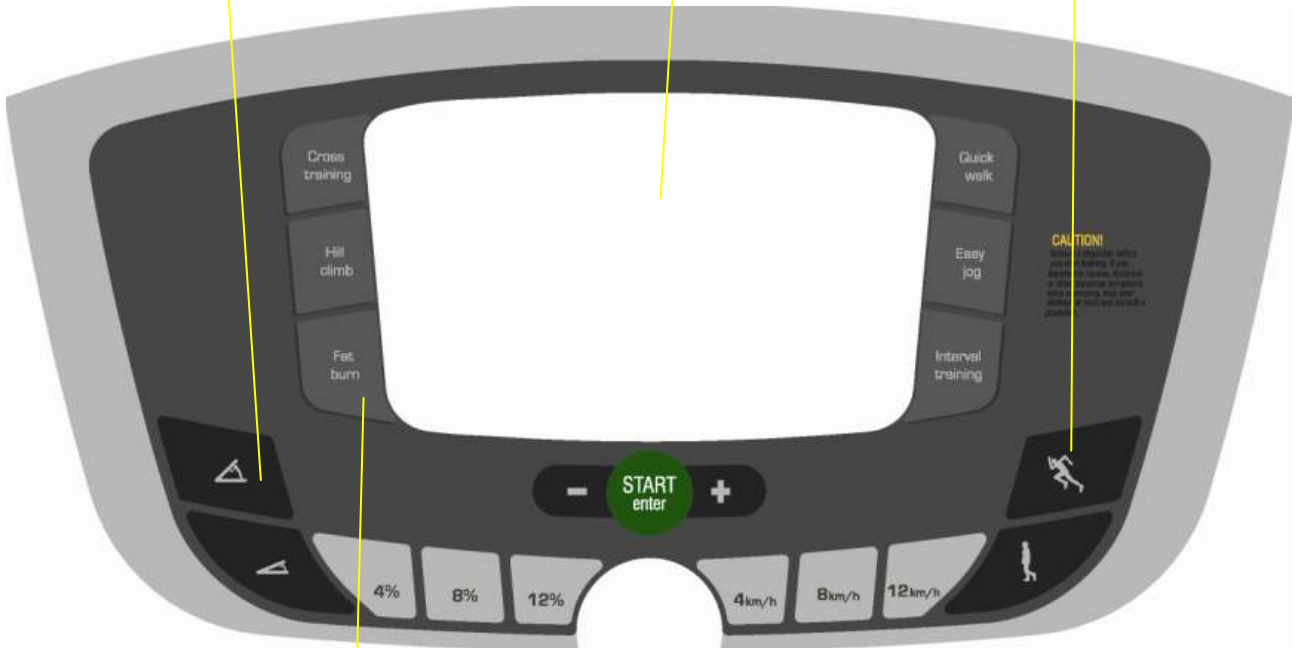

Speed
⏩ increase speed
⏪ decrease speed





6 Quick fitness programs

T501

SPEED ADJUSTMENTS

There are two ways to adjust speed during workout.  and  will adjust speed by increments of 0.1Km/H or you may hold the button to ramp up or down. If the speed adjustment increment is large, it is easier to use the direct speed buttons, which function as direct speed control buttons during the workout. There are three direct speed buttons, 4Km/H, 8Km/H and 12Km/H.

ELEVATION ADJUSTMENTS

 and  will adjust elevation by increments of 1% during workout. Or you may hold these buttons to ramp up or down. If the elevation adjustment increment is large, it is easier to use the direct speed buttons, which function as direct elevation control buttons during the workout. There are three direct elevation buttons 4%, 8% and 12%.

PULSE FUNCTION

This treadmill features wireless heart rate monitoring, the most advanced technology to date for accurate read out of your heartbeat.

To use the wireless pulse monitoring system, you must wear the heart rate transmitter chest strap (sold separately) so that the contact surface is next to your skin directly under your heart to pick up the pulse signals.

Please note that some fibers used in clothes (e.g. polyester, polyamide) create static electricity, which may prevent reliable heart rate measurement. Also note that mobile phone, television and other electrical appliances form an electro-magnetic field around them, which may also cause problems in heart rate measurement.

T501 is also designed to pick up heart rate information via the contact sensors located on the left and right hand rails.

To use the contact heart rate, place your hands gently but firmly around the contact sensors on the hand rails. Movements in the hands may cause difficulty for the treadmill to pick up the signal properly. When signal is picked up, the LCD show flash "HR" signal to the rate of your heartbeat.

PAUSE FUNCTION

When STOP button is pressed during workout, program is suspended. The LCD will display "PAUSE". After the running belt has come to a complete stop, the LCD display window will count down from 3:00. During pause mode, only START or STOP button will function.

If STOP is pressed within three minutes during the pause mode, the treadmill will bring the running belt movement back to the speed at which the treadmill was before paused. Workout values will resume counting and continue where they left off.

If STOP is pressed during the pause mode, the program will end. After three minutes if no button is pressed, the treadmill will automatically end the workout program.

END OF WORKOUT STATS

When you have completed workout or if you have stopped your workout, the LCD window will display twice the following stats: **total time, total distance, total calories and average speed**. Then the display will go to menu mode, ready for the next workout to select. If you wish to skip the workout stats report, simply press the STOP button, which will skip the display to the menu mode.

UNIT CONVERSION

To change from metric to English or English to metric, you must be in the menu mode. Follow the steps below to make the unit conversion.

1. Simultaneously press both the STOP and  together.
2. LCD window will display U-16 (Metric) or U-10 (English).
3. You can select U-16 or U-10 using START/enter button.
4. Push STOP button to confirm.

Once you have begun your workout, the speed unit will have changed the measurement unit accordingly.

FINAL COUNT DOWN

When the workout is selected, the treadmill will activate after 3 seconds.

PRESET PROGRAM

QUICK START

Once the power is turned on and the safety key is secured in place, simply press the START button. Treadmill will activate at 1.0 Km/H after 3 seconds. You may increase or decrease speed or elevation at any time during your workout. To end workout, simply press the STOP button to stop the treadmill.

1. Turn power on
2. Check safety key secured to treadmill and clip secured to user clothing
3. Press START/enter to begin workout

SPEED PROGRAMS

Once the power is turned on and the safety key is secured in place, you may press **??** button to select WALKING PROGRAM or RUNNING PROGRAM or WEIGHT LOSS or HEART STRENGTH. LCD window will prompt user to set up workout duration, and intensity level based on max speed value. Once you have made your selection, press

QUICK START

Once the power is on and the safety tether key is secured in place, simply press the  knob, and after three- second count down treadmill will activate and maintain the running belt at 0.8 Km/H.

START/enter key to activate the treadmill.

During workout, treadmill will automatically adjust speed according to pre-set program settings. User may still be able to adjust speed if the preset is not appropriate. The entire remaining program will scale up or down accordingly. During workout, user may adjust elevation level at will. To end workout, simply press the STOP button to stop the treadmill. During workout, time counts down from target workout time.

1. Turn power on
2. Check safety key secured to treadmill and clip secured to user clothing
3. Press ?? to select ?? for speed program.
4. Press START/enter to confirm
5. Use + and - to input workout duration.
6. Press START/enter to confirm
7. Press + and - to input max workout level (speed).
8. Press START/enter to confirm
9. Begin workout

ELEVATION PROGRAMS

Once the power is turned on and the safety key is secured in place, you may press ?? button to select HILL CLIMB or WEIGHT LOSS or CROSS TRAIN or STEP BY STEP , then press START/enter to activate the treadmill. LCD window will prompt user to set up workout duration, and intensity level based on max elevation value. Once you have made your selection, press START/enter key to activate the treadmill.

During workout, treadmill will automatically adjust elevation according to pre-set program setting. User may still be able to adjust elevation if the preset is not appropriate. The entire remaining program will scale up or down accordingly. During workout, user may adjust speed level at will. To end workout, simply press the STOP button to stop the treadmill. During workout, time counts down from target workout time.

1. Turn power on
2. Check safety key secured to treadmill and clip secured to user clothing
3. Press ?? to select ?? for elevation program
4. Press START/enter to confirm
5. Use to + and - to input workout duration.
6. Press START/enter to confirm
7. Press + and - to input max workout level (speed).
8. Press START/enter to confirm
9. Begin workout

HEART RATE CONTROL PROGRAMS

Users have the option to customize their heart rate control programs based on their target heart rate value. Once the power is turned on and the safety key is secured in

place, you may press ?? to select HEART RATE FAT BURN or Heart Rate Cardio or HEART RATE HILL or HEART RATE INTERVAL. LCD window will prompt user to set up workout step by step. Once you have made your selection, press START/enter button to activate treadmill.

Users also have the option to set up their warm up speed and warm up time. During warm up, target heart rate training function will not be in operation.

After the warm up session, treadmill will automatically adjust by elevation or speed (depending on which program is chosen) to bring the user's heart rate to the targeted heart rate. During workout, users may still be able to adjust speed or elevation. During workout, time counts down from total time, which is defined to be time of warm up, workout and cool down.

At the end of the workout, treadmill will automatically go into cool down. Cool down is pre-set for 4 minutes. In the first two minutes, speed and elevation will be reduced by 50%. The last two minutes, speed will be reduced by another 50% while the elevation will go to 0% grade.

To use the heart rate control programs, user must wear wireless transmitter chest strap. Signals from contact heart rate sensors will not be used in heart rate control programs.

1. Turn power on
2. Check safety key secured to treadmill and clip secured to user clothing
3. Press ?? to select HRC program
4. Display will show program selected
5. Press START/enter to confirm
6. Use + and - to input your age
7. Press START/enter to confirm
8. Use + and - to input workout time
9. Press START/enter to confirm
10. Use + and - to input target heart rate
11. Press START/enter to confirm
12. Use + and - to input warm up time
13. Press START/enter to confirm
14. Use+ and - to input warm up speed
15. Press START/enter to confirm
16. Press START to begin workout

CUSTOM PROGRAM

Once the power is turned on and the safety key is secured in place. You may press ?? to select the USER DATA 1, or USER DATA 2, or USER DATA 3, or USER DATA 4, the user may customize the incline and speed value. Once you have made your data input, press START/enter to activate the treadmill.

When you have completed your workout or if you have stopped your workout, then you can choose to save or not.

1. Turn power on
2. Check safety key secured to treadmill and clip secured to user clothing
3. Select the CUSTOM PROGRAM, then press START/enter
4. Use + and - to input workout time, then press START/enter to confirm
5. Use + and - to input start time of selected location, then adjust the speed or incline value
6. Press START/enter to confirm, program will begin workout

FITNESS TEST PROGRAM

To use the fitness test program, user must wear the wireless transmitter chest strap.

Fitness test is a motivational program designed to determine user's physical fitness level. During workout, user will not be able to adjust speed or elevation. The program will increase workout intensity level. And based on the actual heart rate picked up from the transmitter and the age user inputs, the treadmill computer will be able to assess user's physical fit level.

You may select HR CONTROL PROGRAM on the menu mode, to choose the profile FITNESS TEST. Then press START/enter to activate the treadmill.

1. Turn power on
2. Check safety key secured to treadmill and clip secured to user clothing
3. Select the HR PROGRAM, then press START/enter
4. Select the FITNESS TEST PROGRAM, then press START/enter to confirm
5. Use + and - to input your age, press START/enter to confirm
6. Use + and - to input your sex, press START/enter to confirm
7. Press START/enter to confirm, program will begin workout

VII. EXERCISE TIPS AND GUIDELINES

STRETCH

CAUTION!

Always consult your physician before beginning any exercise program.

Stretching prior to exercise will improve flexibility and reduce chances of exercise related injury. Ease into each of these stretches with a slow gentle motion. Hold for a count of 10. DO NOT bounce. Repeat the stretch exercises again after cool down will help to loosen and relax your muscles to prevent soreness.

WARM UP

The first five minutes of a workout should be devoted to warming up. This warm up will limber your muscles and prepare them for more strenuous exercise. Warm up on the treadmill by walking at slow speed.

COOL DOWN

NEVER stop exercising suddenly. A cool down period of about 5 minutes will allow your heart to re-adjust to the decreased demand. Use a low speed setting during the cool down to gradually lower your heart rate.

HOW OFTEN ?

It is most often recommended that you exercise at least three to four times a week to maintain cardiovascular fitness. If you have other goals such as weight loss or fat loss, you will achieve your goal faster with more frequent exercise. Whether it is three days or six days, remember that your ultimate goal should be to make exercise a lifetime habit.

HOW LONG ?

For aerobic exercise benefits, it is recommended that you exercise for about thirty minutes per session. Always Dial Switch slowly, especially if you have been sedentary during the past year. In the beginning, you may begin with as little as 5 minutes per session. Your body will need time to adjust to the new activity. As your body adjusts, gradually increase your workout time per session.

If your goal is weight loss, a longer exercise session at lower intensities has been found to be most effective. A workout time of 45-50 minutes or more is recommended for best weight loss results.

CAUTION!

For your health and safety, DO NOT over exert yourself.

CAUTION!

If you experience chest pains, nausea, dizziness or shortness of breath, STOP exercising immediately and consult your physician before continuing.

HOW HARD?

How hard you work out is determined by your goal. Regardless of your fitness goals, always begin an exercise program at low intensity. Aerobic exercise does not have to be painful to be beneficial !

There are two ways to measure your exercise intensity. The first is by evaluating your perceived exertion level and the second is by monitoring your heart rate.

During exercise, if you cannot maintain a conversation without gasping, you are working too hard. A good rule of thumb is to work to the point of exhilaration, not exhaustion. If you cannot catch your breath, it is time to slow down. Always be aware of other warning signs of overexertion.

To monitor your heart rate you can use a pulse monitor or take your pulse with your fingers. Pulse monitors are convenient tools for monitoring your heart rate. However, these values are for reference only. You should always listen to your body first.

You can measure your pulse with your fingers by placing your first two fingers lightly over the blood vessel (carotid artery) on your neck located next to your Adam’s apple. Count your pulse for ten seconds and multiply by six. This figure is your heart rate in beats per minute. Compare this number to the Target Heart rate zone for your age group.

TARGET HEART RATE

Age	Target Zone (60% - 75%)
20	120 - 150
25	117 - 146
30	114 - 142
35	111 - 138
40	108 - 135
45	105 - 131
50	102 - 127
55	99 - 123
60	96 - 120
65	93 - 116
70	90 - 113

CALCULATING YOUR TARGET HEART RATE ZONE

The most common method for calculating your target heart rate is to find your maximum heart rate. The standard formula is: 220 - your age = maximum heart rate.

You DO NOT want to work out at your maximum heart rate. Instead you should work out in your target heart rate zone. Your target heart rate zone is a percentage of your maximum heart rate. The AHA (American Heart Association) recommends working out at a target heart rate zone of between 60% - 75% of your maximum heart rate. If you are just beginning a program, exercise near or below the lower limit of your target zone.

Lower limit of target zone = maximum heart rate x 0.60

Upper limit of target zone = maximum heart rate x 0.75

Maximum heart rate (for user age 30) = 220 – 30 = 190

60% of max HR = 190 x .60 = 114

75% of max HR = 190 x .75 = 142

If you have not been exercising on a regular basis, it is recommended that you Dial Switch slower. It may be advised that you use 114 to begin as your target heart rate. If you find this pace too difficult to maintain, go to a lower target heart rate. As you become stronger, you may want to increase your target heart rate.

VIII. MAINTENANCE

CLEANING

DANGER!

To reduce the risk of electrical shock, always unplug the treadmill from the electrical outlet immediately after use and before cleaning.

Remove dust on the treadmill with vacuum or slightly damp cloth. Fold up the deck and clean the floor with vacuum periodically will help to prolong the treadmill product life.

NEVER use solvents on the deck or running belt. Use of solvents can reduce critical lubrication of the deck and belt.

RUNNING BELT CENTERING ADJUSTMENT

When you run or walk, you may push off harder with one foot than the other. This will cause the running belt to run off centered. This treadmill is designed and built to ensure proper tracking of the belt is always centered on the deck. Occasionally the belt may need further adjustment to keep it centered. To center the belt, use the enclosed Allen wrench to adjust the rear roller position.

BELT CENTERING PROCEDURE

1. DO NOT wear loose clothing, neckties or loose jewelry while making this adjustment.
2. NEVER turn the bolt more than 1/4 turn at a time.
3. Always tighten one side and loosen the other to prevent over tightening or over loosening the belt.
4. Run the treadmill. Adjust belt while the treadmill is running at 4 Mi/H (6.4 Km/H) with no person on the belt.

After making the adjustment, walk on the belt for five minutes to test. If necessary, repeat the procedure but NEVER turn the bolts more than 1/4 turn at a time. Over tightening the belt can significantly shorten the belt life.

IF BELT TOO FAR TO THE LEFT SIDE:

1. Turn the left roller bolt 1/4 turn clockwise (tighten)
2. Turn the right roller bolt 1/4 turn counterclockwise (loosen)

IF BELT TOO FAR TO THE RIGHT SIDE:

1. Turn the right roller bolt 1/4 turn clockwise (tighten)
2. Turn the left roller bolt 1/4 turn counterclockwise (loosen)

CAUTION!

Over tightening of the belt will severely shorten the life of the belt and may cause further damage to other components.

RUNNING BELT TENSIONING ADJUSTMENT

If you place your feet on the belt and feel a slipping sensation, then the belt has stretched and is slipping across the rollers. All belts will stretch over time. This is a normal and common adjustment on any treadmill. To eliminate this slipping, tension both Allen bolts on the rear roller 1/4 turn. Try the treadmill again to check for slipping. Repeat if necessary, but NEVER turn the roller bolts more than 1/4 turn at a time.

DRIVE BELT TENSIONING ADJUSTMENT

If you have tensioned the running belt and are still experiencing a slipping sensation, call your dealer. Only an authorized dealer should perform tensioning of the drive belt.

LUBRICATING THE DECK

A well-lubricated deck will ensure high performance of your treadmill and reduce the level of normal wear and tear to important components. This treadmill has been pre-lubed at the factory. However, for optimal performance, the running deck may require periodic lubrication. With average usage (30 minute workout at 5-6 Km/H 3 times a week for two people) lubricate every six months. You may adjust the timing of the lubrication based on the intensity of the treadmill use level.

To check the lubrication level, simply lift the running belt, and put your hand as far into the center of the belt as you can reach. If your hand shows signs of silicone, then it does not need additional lubrication. If the board feels dry and there is very little evidence of silicone on your hand, then additional lubrication should be added.

TO LUBRICATE THE DECK:

1. Stop running belt so that the seam is located on top and in the center of the deck.
2. Insert nozzle into spray head of lubricant can.
3. Lift running belt.
4. Position nozzle between the belt and the board approximately 200mm (8") from the front of the treadmill.
5. Apply the silicon from the front to the rear of the treadmill on each side of the treadmill. Try to reach the spray as far into the center of the running deck as possible. The spray time should be approximately four seconds for each side.
6. Spread the silicon by running the treadmill at 1 Km/H and step gently on the belt from left to right. Do that for a few minutes and allow the silicon to soak into the belt.

NOTE!

A well lubricated deck will ensure longevity of your treadmill in addition to providing you with the optimal performance.

IX. TROUBLE SHOOTING

WHEN TO CALL FOR HELP

This treadmill is designed with user safety as the number one priority. In the event of electrical failure, the treadmill will shut off automatically to prevent user injury and to prevent damage to expensive components such as the motor.

When you encounter unusual behavior from the treadmill, simply go to the front of the treadmill and turn the power switch off and on to reset the treadmill. This should clear incidental errors and ready the treadmill for normal operation again.

If you have reset the treadmill by turning the power switch off and on again, and the treadmill is still not operational, then it is time to call your dealer for service.

TROUBLE SHOOTING GUIDE

Problem	Potential cause	Corrections
Treadmill will not Dial Switch	<ol style="list-style-type: none"> 1. Not plugged in 2. Safety tether key not inserted 3. House circuit breaker tripped 4. Treadmill circuit breaker tripped 5. Switch on OFF 	<ol style="list-style-type: none"> 1. Plug into grounded outlet. 2. Insert safety tether key into console. 3. Reset or replace fuse. 4. Lubricate treadmill deck and reset. 5. Turn switch to ON
Running belt slips	<ol style="list-style-type: none"> 1. Running belt not tight enough 2. Drive belt not tight enough 	<ol style="list-style-type: none"> 1. Adjust running belt tension 2. Adjust drive belt tension
Running belt hesitates when stepped on	<ol style="list-style-type: none"> 1. Insufficient lubrication 2. Running belt too tight 	<ol style="list-style-type: none"> 1. Apply silicone lubricant 2. Adjust running belt tension
Running belt is off centered	Running belt tension not even across the rear roller	Center the running belt

Adjust the speed easily with your thumb while

X. WARRANTY

TERMS AND CONDITIONS

This warranty is valid only in accordance with the conditions set forth below. Warranty applies only while the followings three conditions are met.

- It remains in the possession of the original purchaser and proof of purchase is demonstrated.
- It has not been subject to accident, misuse, abuse, improper service or unauthorized modifications.
- Claims are made within the 12 months manufacturer's warranty period.

EXCLUSIONS AND LIMITATIONS

This warranty is for home use only. Under no circumstances is this treadmill warranted for semi-commercial or commercial use.

We warrant this product to be free from defects in material and workmanship. This warranty is expressly limited to the replacement of a defective motor, electronic components, or defective parts and is the sole remedy of the warranty. Labor for repair or replacement of defective parts is not covered by this warranty. The warranty does not cover normal wear and tear, improper assembly or maintenance or installation of parts or accessories not originally intended or compatible with the treadmill sold. The warranty does not apply to damage or failure due to accident, abuse, corrosion or neglect.

Manufacturer shall not be responsible for incidental or consequential damages.

WARRANTY REGISTRATION

The warranty registration must be completed in full. Send or fax this information along with a proof of purchase to your dealer to keep on file. Your dealer must have this information on file before a warranty claim can be processed.

WARRANTY REGISTRATION – Keep a copy for your records	
Model #: _____	Serial #: _____
Date of purchase: _____	Your name: _____
Dealer name: _____	Address: _____
Dealer address: _____	